

MERMAC A

Dynamic and versatile LARS solutions

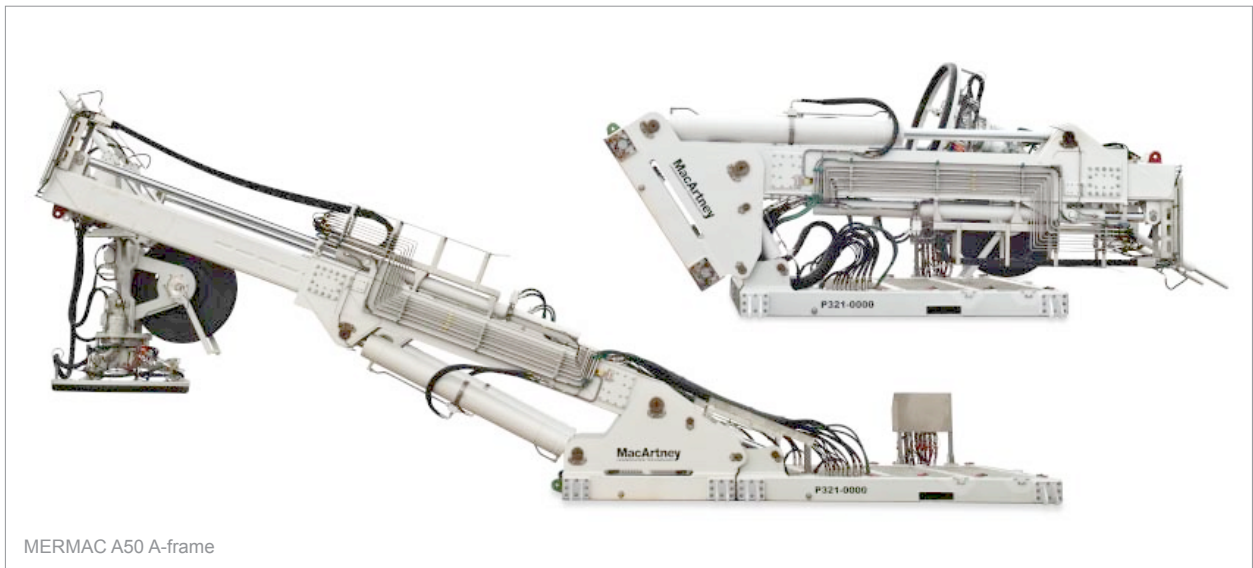

MERMAC A50 A-frame

The MacArtney range of dynamic MERMAC A launch and recovery system (LARS) solutions include A-frames, davits and other solutions for providing reliable and fully controllable deployment and recovery of a wide range of equipment - from small oceanographic instruments to large work class ROV systems. MERMAC A LARS solutions can be designed as portable or fixed systems and form part of compact and fully integrated winch and handling solutions onboard almost any type of vessel.

Standard MacArtney MERMAC A-frame models range from the MERMAC A10 compact and portable A-frame handling system to the powerful and uniquely foldable MERMAC A50. The MERMAC A10 is designed to incorporate MacArtney CORMAC Q winches for efficient handling of inspection ROVs, side scan sonar, survey equipment, oceanographic instrumentation and a wide range of other marine equipment. MERMAC A10 systems are easy to control and provide the outreach needed for safe launch and recovery. The systems can be supplied with or without a power unit.

At the other end of the range, the MERMAC A50 is a 120kN A-frame primarily designed for handling TMS based work class ROV systems. The system design features an industry unique extra skid joint which allows the frame to fold at an extreme angle to enter transportation or deck access mode. The MERMAC A50 system is delivered with a fully integrated docking head with latching mechanism and rotating function.

Beyond the A10 and the A50, the MacArtney MERMAC A range also spans everything from basic over-the-side handling systems, including J-frames and davits, to much more advanced systems such as articulating A-frames, 45° launch position A-frames, horizontal launch position A-frames, low dip A-frames and container integrated A-frame solutions.

Applications

- Work class ROV systems
- Inspection class ROV systems
- Towed vehicles and instrumentation platforms
- Side scan sonar systems
- Oceanographic systems, sensors and equipment
- Seabed drilling and sampling systems
- Light handling and support for subsea completion
- General marine instrumentation

Options

- Certification according to DNV 2.7-3
- Certification according to DNV 2.22
- Docking head
- Hinged base system for easy transport
- Extension on main legs
- Pitch/roll on docking head
- Remote control/wireless remote control
- Spares packages
- Service packages

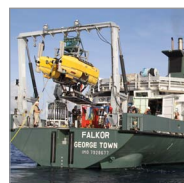

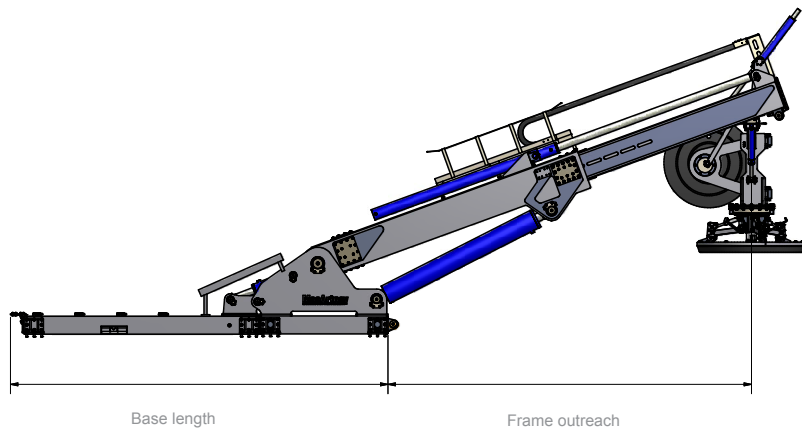
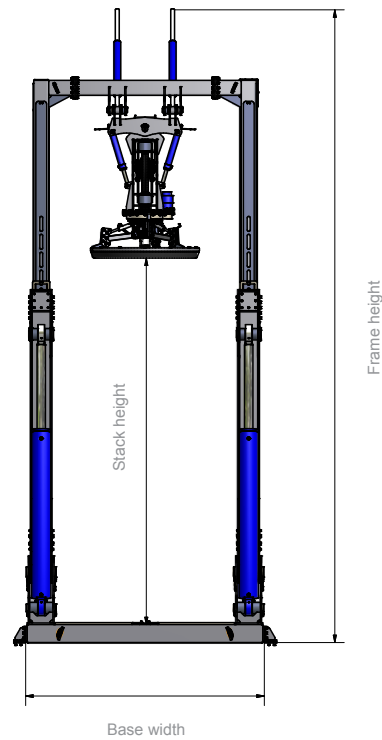

Specifications

	SWL	Design factor	DNV 2.22	Docking head	System weight	Base width	Base length	Frame height	Stack height	Frame outreach
model	kN	-	-	-	ton	mm	mm	mm	mm	mm
MERMAC A10	8 kN	3	yes	no	2	2,075	2,500	5,945	5,180	3,500
MERMAC A20	30 kN	3	yes	yes	8.5	2,860	6,040	6,770	4,195	3,960
MERMAC A45	89 kN	2.5	yes	no	7.7	7,440	1,605	6,400	6,000	4,700
MERMAC A50	120 kN	3	yes	yes	19.5	3,990	6,485	10,610	6,135	6,080