

- NEAR OCTAVE BANDWIDTH
- OMNI-DIRECTIONAL RESPONSE
- EFFICIENT TRANSMITTER
- HIGH POWER PROJECTOR
- DEEP WATER CAPABILITY

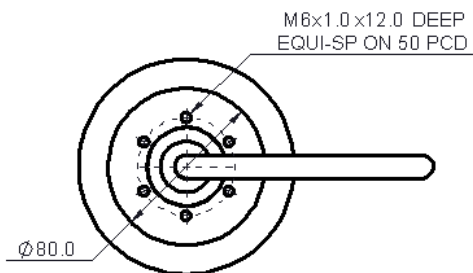
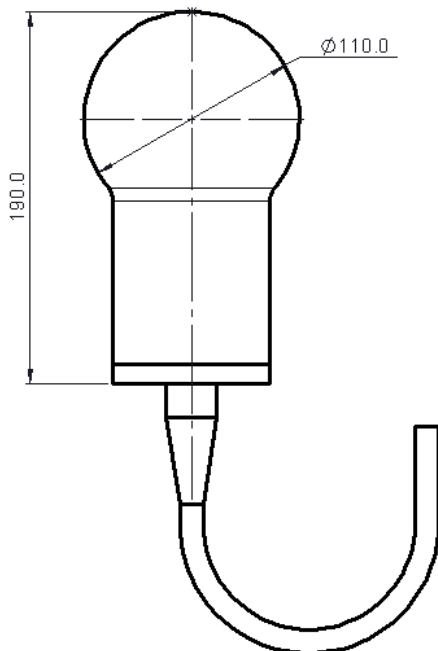
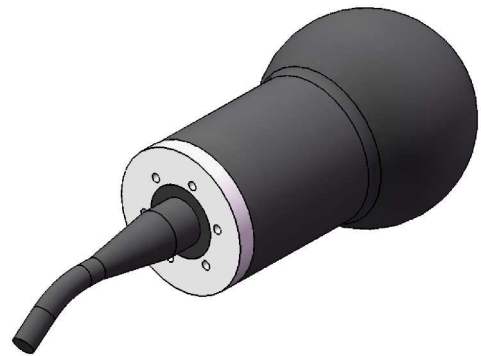

All dimensions in mm

The D/I7/BB is a wide band, highly efficient, omni-directional transmit and receive transducer.

With a -3db bandwidth from 11 kHz to 26 kHz the D/I7/BB transducer is ideally suited for use in broadband noise systems, long-range transponder applications, marine mammal deterrents and voice/data comms systems.

The robust construction enables the transducer to operate in extreme underwater environments and withstand high mechanical and explosive shock levels.

Electrical connection to the transducer is by a 2 core screened polyurethane cable.

The transducer can be mounted to customer equipment packages using the six fixing holes.

The D/I7/BB is available with or without acoustic calibration. All calibrations are traceable to National Standards.

Technical Specification

Frequency Band (-3dB)	11 to 26 kHz
Beam Pattern	Omni
Transmit Sensitivity	See Graph
Input Power	2000 Watts around resonance
Operating Depth	2000 Metres
Operating Temperature	-5 to +40 °C
Storage Temperature	-40 to +80 °C
Cable Type	Polyurethane Ø12mm 2 Core Screened
Cable Length	10 metres standard Additional lengths supplied to order

Receive Graph

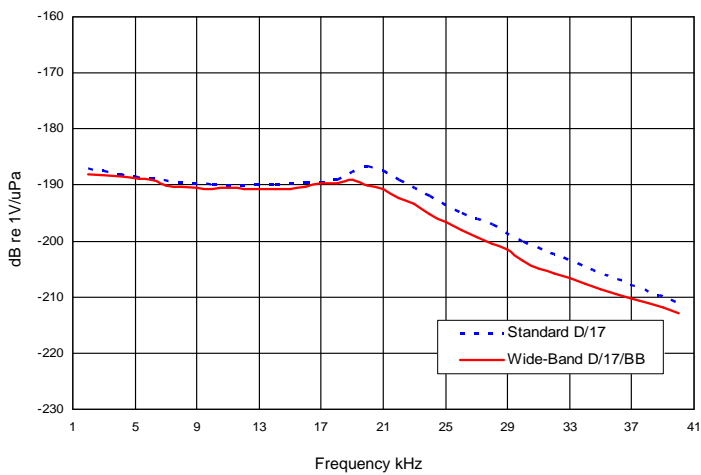

Admittance Plot

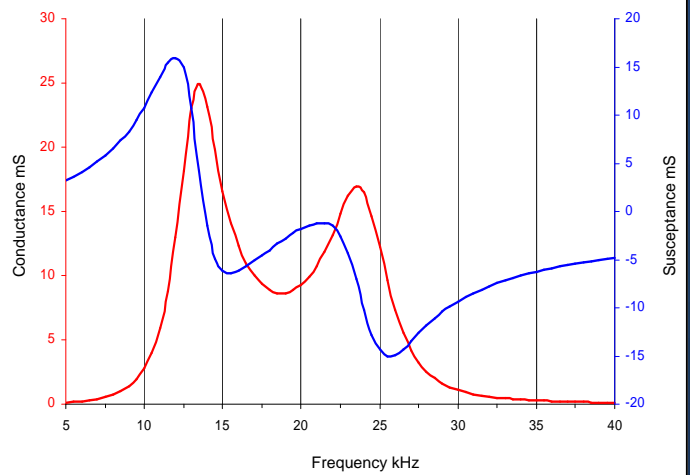

Transmit Graph

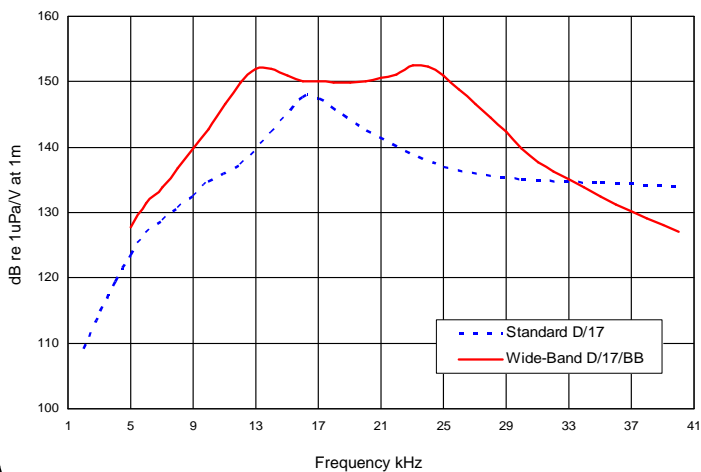

Beam Pattern at 17 kHz

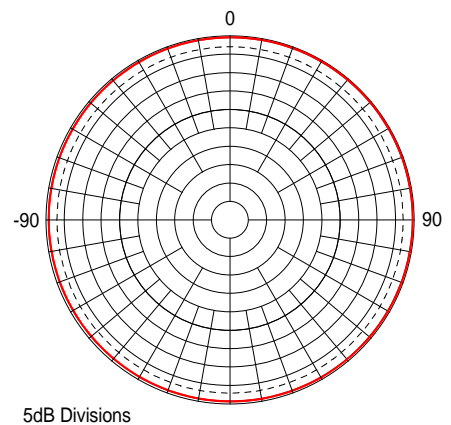

Data illustrated is taken from actual in-water measurements